



KLE Society's

S. Nijalingappa / Independent PU College

II Block, Rajajinagar, Bangalore-10

Phone: 080-23526055, 080-23325020

Website: www.klesncpu.edu.in

Fax: 080-23320902

E-mail: klesncpuc@gmail.com

MODEL QUESTION PAPER - III

Class : II PU	Subject : Electronics	Subject Code : 40
Year : 2020 – 21	Duration : 3 hour 15 minutes	Maximum Marks : 70

- Note:** 1) Question paper has **four** parts **A,B,C** and **D**.
2) Part-**A** is **compulsory**.
3) Part-**D** has **two** parts. Part-**I** is from **problems**, Part-**II** is of **essay type** questions.
4) Circuit diagrams/timing diagrams/truth tables are drawn **wherever** necessary.
5) Problems without necessary formula/formulae carry **no** marks.

PART A

Answer all questions.

10 X 1 = 10

1. Define transconductance.
2. What is leakage current?
3. What is dc load line?
4. Write the expression for efficiency of power amplifier.
5. What is the use of R_E in CE amplifier?
6. Mention any non-linear application of op-amp.
7. Draw the symbol of crystal.
8. What is fading?
9. Write the expression for power of AM wave.
10. Convert 1101_2 into gray code.

PART B

Answer any FIVE questions

5 X 2 = 10

11. The pinch off voltage of FET is -3V. For a gate to source voltage -2V drain current is 5mA. Calculate drain to source saturation current.
12. Mention the biasing conditions for normal operation of transistor amplifier.
13. Draw the pin configuration of IC741.
14. Determine the output voltage of a non- inverting amplifier given $V_{in}=2.5V$, $R_F=10K\Omega$ and $R_i=3.3K\Omega$.
15. Mention any two advantages of crystal oscillator.
16. Write a short note on noise.

17. Realise XNOR gate using basic gates.
18. Write the truth table for 3 variable input with min term designations.

PART C

Answer any FIVE questions.

5 X 3 = 15

19. Mention the differences between BJT and FET..
20. Explain the terms thermal runaway, leakage current and heat sink.
21. Explain the principle of amplification.
22. Compare different types of coupled amplifiers.
23. The open loop gain and closed loop gain of an amplifier are 200 and 100 respectively. Calculate the feedback fraction.
24. Explain the concept of virtual ground in an op-amp.
25. Explain the concept of ground wave propagation.
26. Write a note on Excess-3 code.

PART D

I. Answer any THREE of the following.

3 X 5 = 15

27. For the given CE amplifier circuit using germanium transistor, find: a) V_2 b) I_E c) $r_{e'}$ d) $Z_{in(base)}$ e) A_v . Given $\beta=100$, $r_{e'}=52mV/I_E$.

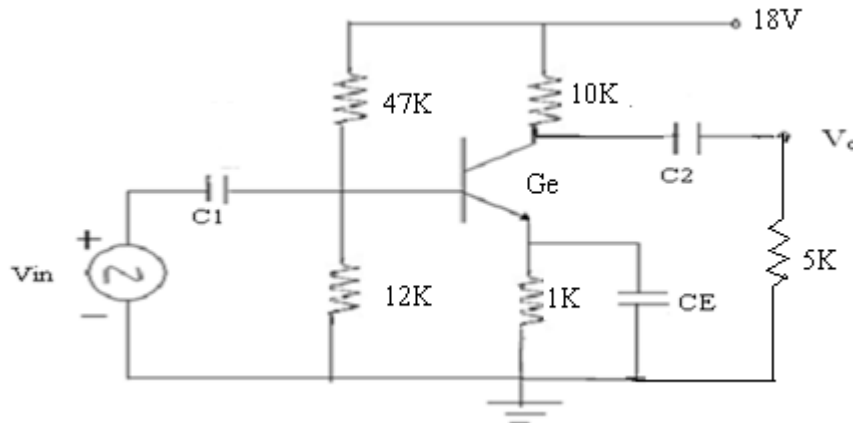

28. Find the output voltage of the following circuit shown below

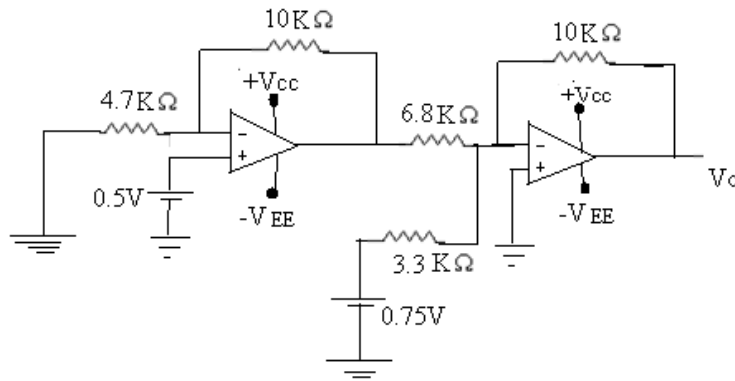

29. The frequency of Colpitts oscillator is 18MHz. Design the value of inductor to be used if $C_1=100\text{pF}$ and $C_2=10\text{pF}$.

30. A carrier wave of 10MHz and peak voltage of 14V is amplitude modulated by a sine wave of 5KHz and amplitude 6V. Write the equation of the AM wave and what is the bandwidth of modulated signal?

31. Simplify the following Boolean expression by using K-map.
 $Y = \sum m(0, 2, 4, 6, 8, 10, 11, 12, 14, 15) + \sum d(9, 13)$
 Draw the logic circuit for the simplified expression using basic gates.

II. Answer any FOUR of the following. 4 X 5 = 20

32. With a circuit diagram explain the working of CE amplifier.
33. Obtain the expression for input impedance of voltage series negative feedback amplifier.
34. Derive an expression for the output of op-amp integrator with a circuit.
35. Draw the circuit diagram of phase shift oscillator and explain its working.
36. Derive an expression for power of an AM wave.
37. Explain the working of SR with logic circuit and truth table.